

## Article

# University Students' Procrastination: A Mathematical Model (Case Studies: Student in Mathematics Department Universitas Negeri Padang)

### Article Info

#### Article history :

Received March 30, 2022  
Revised May 30, 2022  
Accepted June 07, 2022  
Published June 30, 2022

#### Keywords :

Procrastination,  
SEIR modelling,  
basic reproduction  
number

Rara Sandhy Winanda<sup>1\*</sup>, Akira Mikail<sup>2</sup>, Defri Ahmad<sup>3</sup>, Dina Agustina<sup>4</sup>, Rahmawati<sup>5</sup>

<sup>1,2,3,4</sup>Department of Mathematics, Faculty of Mathematics and Natural Science, Universitas Negeri Padang, Padang, Indonesia

<sup>5</sup>Department of Mathematics, Faculty Science and Technology, Universitas Islam Negeri Sultan Syarif Kasim Riau

**Abstract.** Mathematical modelling of procrastination was carried out on students in the Mathematics Department at Universitas Negeri Padang. Procrastination is the tendency to delay work and can be contagious among students. Mathematical modelling of procrastination aims to show the spread of procrastination among students. The SEIR compartment model was applied in this study. From a total of 1,154 population members, 93 samples were randomly selected and were given a questionnaire to estimate the parameter values in the model. A couple of steady states appear in the model. The free disease steady state has a biological meaning since all the variables are real, while the endemic steady state is surreal in biological terms. The number of its basic reproduction number, from which the parameter values are derived from the primary data, indicates stability analysis near the free disease steady states. The result shows that procrastination is spread among students in the population, with the number of  $R_0$  is 1,009.

*This is an open access article under the [CC-BY](https://creativecommons.org/licenses/by/4.0/) license.*



This is an open access article distributed under the Creative Commons 4.0 Attribution License, which permits unrestricted use, distribution, and reproduction in any medium, provided the original work is properly cited. ©2022 by author.

#### Corresponding Author :

Rara Sandly Winanda  
Department of Mathematics, Faculty of Mathematics and Natural Science (FMIPA),  
Universitas Negeri Padang, Padang, Indonesia  
Email : [rarawinanda@fmipa.unp.ac.id](mailto:rarawinanda@fmipa.unp.ac.id)

## 1. Introduction

Procrastination is defined as the deliberate, unjustified delay of a planned course of action while understanding that the delay would have negative consequences [1]. It's a typical occurrence in everyday life, and it's tied to poor time management skills. Prevalence rates in the general population range between 46 and 52 percent in some studies, and between 80 and 95 percent in others. As a result, procrastination is not a subject to be treated lightly; rather, it should be regarded seriously because its prevalence in society is quite high and increasing. Procrastinators, or individuals who put off tasks, are fully aware that they are doing it. They exhibit lower levels of self-efficacy [2]. The activity is postponed in order to produce feelings of discomfort, worry, and fear [3].

Academic procrastination, such as drafting a report or studying for an exam, is far more prevalent among university students. In an academic setting, data suggests that between 50–70% of college students engage in regular and severe procrastinating behaviour [4]. It is typically achieved by relaxing, reading, or watching television. Smartphone addiction was also linked to academic procrastination [5]. Recent research supports the idea that academic procrastination can be viewed as a situational failure in learning self-regulation. It shows that therapies should target both situational and self-regulation weaknesses in order to help students overcome their procrastination inclinations [3]. The current review looked at the most recent research on the causes and consequences of academic procrastination as well as the small number of studies on academic therapies for academic procrastination [6]. Social support and resilience are thought to have a significant impact on students' academic procrastination [7]. In studies, procrastination has also been linked to lower academic success.

Procrastination can also be passed down from one person to the next. It can be transmitted by causing individuals to be distracted and preventing them from accomplishing their duties, particularly if they are in the same location [8]. Procrastination was negatively related to academic performance and academic life satisfaction. Male students had higher levels of academic procrastination and lower levels of academic performance and academic life satisfaction [9]. As shown by significant differences, task aversiveness, time management, laziness, rebellion against control, decision-making, and lack of assertion were more common in students of social sciences than in natural sciences, as shown by significant differences. Overall, task aversiveness, fear of failure, dependency, decision making, and risk-taking were common reasons for indulging in academic procrastination [10].

Mathematical modelling studies typically address complex situations and tend to rely more heavily on assumptions about underlying mathematical structure than on individual-level data [11]. Mathematical psychology is the discipline of psychology that focuses on using mathematical and computational models to understand and predict human behaviour. Memory, attention, problem solving, perception, decision making, and motor control are typical topics of focus. The field arose from measuring issues faced in psychophysics, with a focus on behavioural reactions [12].

In order to fully appreciate the nature of this phenomenon, we developed a mathematical model to quantify the prevalence of procrastination among university students. These modelling issues are based on epidemiological models. SIR, SIIR, SIRS, and SEIRS are a couple of examples [13], [14], [15], [16], [17], [18], [19]. The SEIR comparison is used to model the circumstances (Susceptible, Exposed, Infectious, Recovered). A group of students suspected of procrastination is referred to as susceptible. Incoming students are placed in the same section in this case. Students who have been exposed to the habit but do not spread it to others are known as exposed students. The term "infected" is used to describe a group of infected students. "Infected" refers to a student who has picked up the habit and passed it on to others. Students that have not displayed procrastination are classified as "recovered compartment."

## 2. Experimental Section

This research is classified as "theoretical research," which is defined as research that aims to improve science by inventing or discovering new theories. This research aims to develop a theory on how procrastination spreads. A descriptive method was applied, which is described as a procedure for solving the problem under consideration. Questionnaires are distributed to the research sample, and primary data is collected. In this study, the following actions were taken:

1. Identify and resolve procrastination issues among students at Universitas Negeri Padang's Mathematics Department.
2. Collect and examine relevant theories on the subject.
3. Determine the variables and parameters that will be used.
4. Establish the assumptions that will be used to construct the model.
5. Construct a mathematical model of the issue.
6. Use stability analysis near the steady states.
7. Design the questionnaire.
8. Verify the data.
9. Distribute the questionnaire.
10. Analyse the results.
11. Give an interpretation.
12. Perform a numerical simulation.
13. Provide a conclusion.

The population of this study is students of the Mathematics Department at Universitas Negeri Padang in the academic year 2021/2022. The population consists of 1,154 students, and the sample was selected randomly using the Slovincs formula [20], resulting in a total of 93 students. The research instrument used is a closed questionnaire by Likert scale. In the research, we used a five-point scale for all items of the question. To measure the academic procrastination parameters, we constructed the outline of the questionnaire. The outline was reviewed by psychology and mathematics experts before it was distributed. These are the outlines

**Table 1.** Outlines of the Questionnaire

<b>Variables</b>	<b>Sub-Variables</b>	<b>Indicator</b>
Academic procrastination	1. Procrastination infectious rate	a. Ignore the tasks b. Idleness
	2. Rates of transmission from latent to infectious	a. Soothe the workload b. High expectations
	3. Recovered rate	a. awareness of oneself
	4. The ability to raise one's own standard of living	a. Change the habit b. Do not be affected by the surroundings.

The questionnaire consists of 17 questions. The first question aims to classify the student into four compartments as the initial condition. While the remains are grouped into four sub-questions due to four parameters that arise in the model, before the questionnaire was distributed, we conducted a test on 30 respondents. Validation and reliability checks are performed on the results.

### 3. Results and Discussion

#### 3.1. The model

The following are the assumptions that were used to create the model:

1. Closed population. In this research, we collected data from students' universities in the academic year 2021–2022.
2. Students who are susceptible will be infected by the procrastinator and enter an exposed compartment.
3. When exposed to an infected compartment, the infection rate remains constant.
4. The healthy rate in the exposed compartment is constant.
5. Procrastination can be recovered.
6. Students who have recovered from infection are at risk of re-infection.

We discovered four variables during the study (Susceptible, Exposed, Infected, and Recovered).

While the following are parameters:

1. Death due to natural causes ( $\mu$ ).
2. Incidence rate of contact between students in susceptible and infected compartment ( $\beta$ ).
3. The rate at which a susceptible enters an exposed compartment without being affected by others ( $\gamma$ ).
4. The infectious rate as a result of being exposed to an infected compartment ( $\epsilon$ ).
5. Rate of recovery ( $\delta$ ).
6. Rate of reinfection ( $\sigma$ ).

This diagram illustrates the model

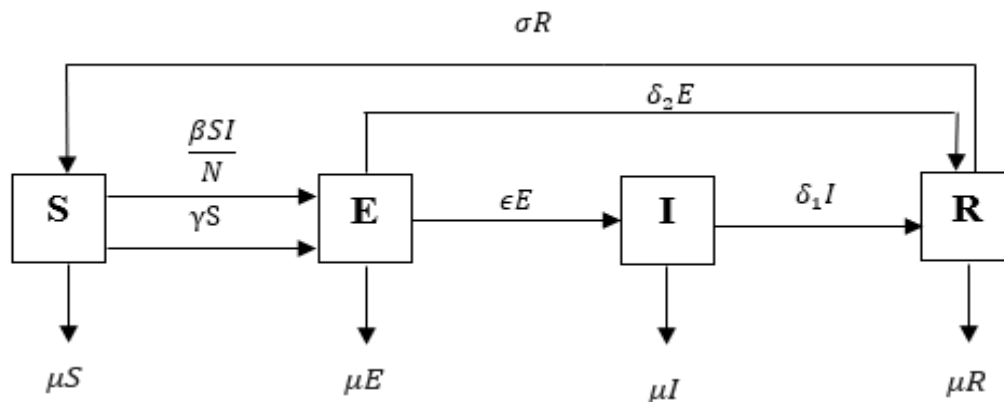

**Figure 1.** Diagram of Procrastination Spreading among University Students Compartment Model

The following equations represent the mathematical models of the problems.

$$\frac{dS}{dt} = \sigma R - \frac{\beta SI}{N} - \gamma S - \mu S \quad (1)$$

$$\frac{dE}{dt} = \frac{\beta SI}{N} + \gamma S - \epsilon E - \delta_2 E - \mu E \quad (2)$$

$$\frac{dI}{dt} = \epsilon E - \delta_1 I - \mu I \quad (3)$$

$$\frac{dR}{dt} = \delta_1 I + \delta_2 E - \sigma R - \mu R. \quad (4)$$

$$S(0) = S_0, E(0) = E_0, I(0) = I_0, R(0) = R_0$$

### 3.2. Stability Analysis

The analysis is carried out by establishing the steady states and stability of systems (1)-(4). The basic reproduction number is used to keep track of how procrastination spreads within the population. By setting  $\frac{dS}{dt} = 0, \frac{dE}{dt} = 0, \frac{dI}{dt} = 0, \frac{dR}{dt} = 0$ .

Free disease and endemic steady states are the coupled steady states for Systema (1)–(4). Free disease steady states indicate the points that have no procrastination in the population, or mathematically, this point is discovered when  $I = 0$ . System (9)-(12) specifies the point as  $e_0 = (0,0,0,0)$ . While, the endemic steady state shows that procrastination is spreading widely among the population. The endemic steady state doesn't exist in biological phenomena, since there are negative values for compartments E, I, and R. Thus, we only analyse the behaviour of a solution near the free disease steady state.

To determine the stability of the steady states, we use linearization by using a Jacobian Matrix that is evaluated in the steady states. According to [21] for the nonlinear system, if all the eigenvalues are positive, then the steady states are asymptotically stable. Here are the Jacobian Matrices for Systems (1)-(4).

$$J = \begin{bmatrix} -\frac{\beta I}{N} - \gamma - \mu & 0 & -\frac{\beta S}{N} & \sigma \\ \frac{\beta I}{N} + \gamma & -\epsilon - \delta_2 - \mu & \frac{\beta S}{N} & 0 \\ 0 & \epsilon & -\delta_1 - \mu & 0 \\ 0 & \delta_2 & \delta_1 & -\mu - \sigma \end{bmatrix}$$

By applying the Jacobian matrices in free disease steady states as follows, the eigenvalues of the characteristic equation are solved.

$$J(e_0) = \begin{bmatrix} -\gamma - \mu & 0 & 0 & \sigma \\ \gamma & -\epsilon - \delta_2 - \mu & 0 & 0 \\ 0 & \epsilon & -\delta_1 - \mu & 0 \\ 0 & \delta_2 & \delta_1 & -\mu - \sigma \end{bmatrix}$$

Because it contains higher polynomials, the eigenvalues could not be expressed in an explicit formula. It is demonstrated using the Maple 21 program. As a result, we use the concept of the fundamental reproduction number to examine stability.

### 3.3. Basic Reproduction Number

The basic reproduction number ( $R_0$ ), also known as the basic reproduction ratio or rate or the basic reproductive rate, is an epidemiologic statistic used to describe the infectious age's contagiousness or transmissibility [22]. According to the claim, Next Generation Matrix [23] are methods of constructing by evaluating matrices at free stable states. We discovered

$$R_0 = \frac{\beta\epsilon}{(\epsilon + \delta_2 + \mu)(\delta_1 + \mu)} \tag{5}$$

### 3.4. Numerical Simulation

The parameters used in this study were retrieved from the original data using questionnaire techniques. To demonstrate how procrastination affected the population, we approximated the fundamental reproduction number using the parameter values. The values of the parameters are listed below.

**Table 2.** Parameters for the Simulation

Parameters	Grade
$\mu$	0,1470588
B	0,661637931
$\gamma$	0,2434
$\epsilon$	0,615
$\delta$	0,88452381
$\sigma$	0,645454545

We discovered that  $R_0 = 1,008$  indicated that procrastination is becoming more prevalent in the community. We exhibit a numerical simulation towards the steady states using the Matlab 21 programme to confirm the analysis. The solution's trajectory is depicted in Figure 1.

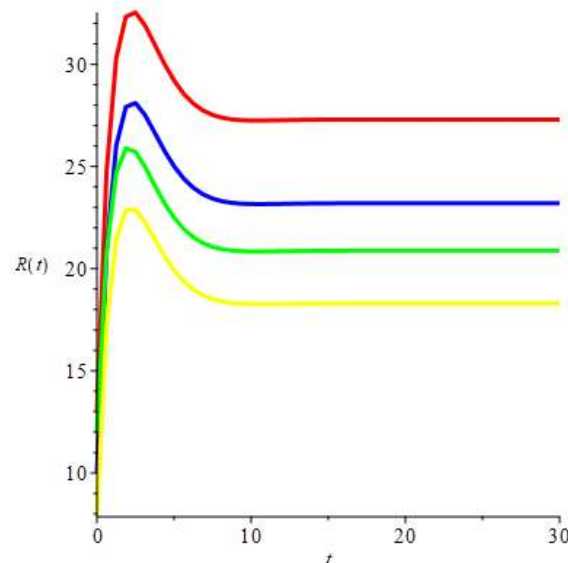
**Figure 1.** Trajectory Diagram near the Steady States

The susceptible, latent, infected, and recovered compartments are represented by blue, red, green, and yellow lines, respectively. By fitting beginning values and parameters based on collected data, it was soon proved that procrastination still existed in the population. As a result, the steady states of free disease are not asymptotically stable.

#### 4. Conclusion

The mathematical model of procrastination that is gaining traction among university students has turned into a dangerous habit that is spreading. We performed the research through case studies with students from the Mathematics Department at Universitas Negeri Padang. The model has two stable states, one of which is biologically irrelevant due to a negative population. To determine stability near the free disease steady state, the fundamental reproduction number is used. The model was numerically analysed using the questionnaire data to set the parameter values. Because  $R_0 = 1,008$ ,

the steady state is not stable. As a result, procrastination is still popular and spreading among students in the Mathematics Department at Universitas Negeri Padang.

## References

- [1] Pinxten, M., De Laet, T., Van Soom, C., Peeters, C., & Langie, G. (2019). Purposeful delay and academic achievement. A critical review of the Active Procrastination Scale. *Learning and Individual Differences*, 73(April), 42–51.
- [2] Cursi Campos, H. (2020). Strategies to Reduce Procrastination in College Students. *Journal of Teaching and Learning with Technology*, 9(1), 101–118.
- [3] Korstange, R., Craig, M., & Duncan, M. (2019). Understanding and Addressing Student Procrastination in College. *Learning Assistance Review*, 24(1), 57–70.
- [4] Küchler, A. M., Albus, P., Ebert, D. D., & Baumeister, H. (2019). Effectiveness of an internet-based intervention for procrastination in college students (StudiCare Procrastination): Study protocol of a randomized controlled trial. *Internet Interventions*, 17(March).
- [5] Li, L., Gao, H., & Xu, Y. (2020). The mediating and buffering effect of academic self-efficacy on the relationship between smartphone addiction and academic procrastination. *Computers and Education*, 159(November 2019), 1–11.
- [6] Zacks, S., & Hen, M. (2018). Academic interventions for academic procrastination: A review of the literature. *Journal of Prevention and Intervention in the Community*, 46(2), 117–130.
- [7] Madjid, A., Sutoyo, D. A., & Shodiq, S. F. (2021). Academic procrastination among students: The influence of social support and resilience mediated by religious character. *Cakrawala Pendidikan*, 40(1), 56–69.
- [8] Baali, H., Khorshidtalab, A., Mesbah, M., & Salami, M. J. E. (2015). A Transform-Based Feature Extraction Approach for Motor Imagery Tasks Classification. *IEEE Journal of Translational Engineering in Health and Medicine*, 3(June).
- [9] Balkis, M., & Duru, E. (2017). Gender differences in the relationship between academic procrastination, satisfaction with academic life and academic performance. *Electronic Journal of Research in Educational Psychology*, 15(1), 105–125.
- [10] Afzal, S., & Jami, H. (2018). Prevalence of Academic Procrastination and Reasons for Academic Procrastination in University Students. *Journal of Behavioural Sciences*, 28(1), 51–69.
- [11] Norris, S. L., Egger, M., Johnson, L., Althaus, C., Schöni, A., Salanti, G., & Low, N. (2018). Developing WHO guidelines: Time to formally include evidence from mathematical modelling studies. *F1000Research*, 6, 1–24.
- [12] Smith, P., Liu, Y., Townsend, J. T., & van Zandt, T. (2020). Mathematical Psychology. *Psychology*, 1–17.
- [13] Kristiani, F., & Samat, N. A. (2019). The mathematical modelling of the SIR-SI contagion model of dengue disease which considers the blood type O factor human compartment : A theoretical simulation. *Journal of Statistics and Management Systems*, 22(3), 425–446.
- [14] Adamu, H. A., Muhammad, M., M.Jingi, A. M., & Usman, M. A. (2019). Mathematical modelling using improved SIR model with more realistic assumptions. *International Journal of Engineering and Applied Sciences (IJEAS)*, 6(1), 64–69.
- [15] Mendes, J., & Coelho, P. (2021). *Generalised SEIR modelling of the COVID-19 pandemic course: data quality issues and structural analysis*.
- [16] Rao, F., Mandal, P. S., & Kang, Y. (2019). Complicated endemics of an SIRS model with a generalized incidence under preventive vaccination and treatment controls. *Applied Mathematical Modelling*, 67, 38–61.
- [17] Naji, R. K., & Thirthar, A. A. (2020). Stability and bifurcation of an sis epidemic model with saturated incidence rate and treatment function. *Iranian Journal of Mathematical Sciences and*

---

*Informatics*, 15(2), 129–146.

- [18] Laosiritaworn, Y., Laosiritaworn, Y., & Laosiritaworn, W. (2018). Herd immunity estimation of flu-like disease spreading in SEIR population: The sociophysics modelling via Monte Carlo simulation on discrete-spin model. *Journal of Physics: Conference Series*, 1144(1).
- [19] Song, P., Lou, Y., & Xiao, Y. (2019). A spatial SEIRS reaction-diffusion model in heterogeneous environment. *Journal of Differential Equations*, 267(9), 5084–5114.
- [20] Briandana, R., & Dwityas, N. A. (2019). Media Literacy: An Analysis of Social Media Usage among Millennials. *International Journal of English Literature and Social Sciences*, 4(2), 488–496.
- [21] Marsden, J. E., Sirovich, L., Antman, S. S., Iooss, G., Holmes, P., Barkley, D., Dellnitz, M., & Newton, P. (1991). Introduction to applied nonlinear dynamical systems and chaos. In *Mathematics and Computers in Simulation* (33),(1).
- [22] Delamater, P. L., Street, E. J., Leslie, T. F., Yang, Y. T., & Jacobsen, K. H. (2019). Complexity of the basic reproduction number ( $R_0$ ). *Emerging Infectious Diseases*, 25(1), 1–4.
- [23] Fosu, G. O., Akweittay, E., & Adu-Sackey, A. (2020). Next-generation matrices and basic reproductive numbers for all phases of the Coronavirus disease. *Open Journal of Mathematical Sciences*, 4(1), 261–272.