

## Article

# Modeling and Simulation Longitudinal Mobile Robotic with Rough Terrain and Ascent Angle Disturbance

### Article Info

#### Article history :

Received March 03, 2020  
Revised May 01, 2020  
Accepted May 05, 2020  
Published June 27, 2021

#### Keywords :

Mobile Robot, Car Like Vehicle Steering, MIMO System, Nonlinear Multivariable System Rough Terrain.

Emilliano<sup>1\*</sup>, Hilwadi Hindersah<sup>2</sup>

<sup>1</sup>Departement of Electrical Engineering, Faculty of Mathematics and Natural Science, Universitas Padjadjaran (Unpad), Jatinangor, Indonesia

<sup>2</sup>Departement of Electrical Engineering, Control Engineering, Bandung Intstitute of Technology (ITB), Bandung, Indonesia

**Abstract.** Model mobile robot that used to this simulation is type car like vehicle steering. Mobile robot type car like vehicle steering is mobile robot that move using force of rear wheel and front rear of mobile robot functions as steering to control direction of mobile robot. The dynamic nonlinear model mobile robot is implemented to view influence disturbance of mobile robot to longitudinal direction mobile robot that used to planetary exploration in rough terrain. The model that used to simulation is nonlinear multivariable MIMO with 5 input and 7 output. The simulation has done by using Simulink of Matlab. The simulations were carried out by giving 4 conditions, namely without disturbance, with an incline angle of 30 (0.5236 rad), with a rough terrain angle of 28.6479 (+0.5 rad), and a combination of 30 incline angle and 28.6479 rough terrain angle. The simulation results with 3 mobile robots show accurate results.

This is an open acces article under the [CC-BY](https://creativecommons.org/licenses/by/4.0/) license.



This is an open access article distributed under the Creative Commons 4.0 Attribution License, which permits unrestricted use, distribution, and reproduction in any medium, provided the original work is properly cited. ©2021 by author.

### Corresponding Author :

Emilliano

Departement of Electrical Engineering, Faculty of Mathematics and Natural Science, Universitas Padjadjaran, Jatinangor, Indonesia

Email : [emilliano@unpad.ac.id](mailto:emilliano@unpad.ac.id)

## 1. Introduction

There are 3 robot cars and 6 disturbances in the simulation for modeling testing. So the research to test the mobile robot model was carried out as many as 18 experiments with interference and 3 experiments without interference. The simulation results of the mobile robot show a decrease in the longitudinal speed of the mobile robot due to disturbances in the plant model, such as incline angle

disturbance, wheel ground contact angle disturbance and both complications. Experiments in simulations have been carried out as closely as possible to follow the real situation of Mars. The simulation results for a wheeled micro-rover traversing Mars-like terrain demonstrate the effectiveness of the algorithm.

The mobile robot model above is a mobile robot type car model such as steering a vehicle. This mobile robot has a rear wheel and a front wheel. This has been driven by the force of the rear wheels, and the front wheel functions as a rudder to move the robot in motion is shown in figure 1.



Figure 1 Mobile robot Rover Mars

## 2. Method

This research develops a dynamic model of a mobile robot with 4 wheels with the type of car like vehicle steering in reference 1 and reference 2, and then it is developed for the case of constant speed control in Longitudinal direction of mobile robots in rough terrain. Reference 1 shows a dynamic system of a mathematical model for a 4-wheeled robot car with a car like vehicle steering type. Reference 2 shows a dynamic system model and simulation that simulates the longitudinal and lateral slip directions of the 4-wheel car-like vehicle steering mobile robot.

In mobile robot testing, a real time testing tool was made with 3 mobile robots using MATLAB Simulink with different parameters and tested using 4 conditions, namely testing without disturbance, with incline angle, and rough terrain angle and a combination of incline angle and rough terrain.

The contribution of this research is to develop a dynamic model of a 4-wheeled mobile robot with a car-like vehicle steering type for the purpose of implementing constant speed rate control in mobile robots. In this study only discussed modeling of longitudinal direction mobile robot 4 wheels without control using 3 mobile robots with 4 conditions.

The following is an explanation of the dynamic system modeling of the mobile robot for the kinematic model of wheel ground contact angle estimation.

### Kinematic Model od Wheel Ground Contact Angle Estimation

To properly formulate the force-distribution equations for wheeled robotics, the wheel-ground contact angles  $\gamma_1$  and  $\gamma_2$  must be known. Below, a method is presented for estimating these contact angles using on-board sensors. As before, each wheel makes contact with the ground at a single point. The vehicle pitch,  $\alpha$  is defined with respect to the horizon, X. The wheel centers have

velocities  $v_1$  and  $v_2$  parallel to the local wheel ground tangent plane due to the rigid wheel-ground assumption. The distance between the wheel centers is  $l$ . [10]

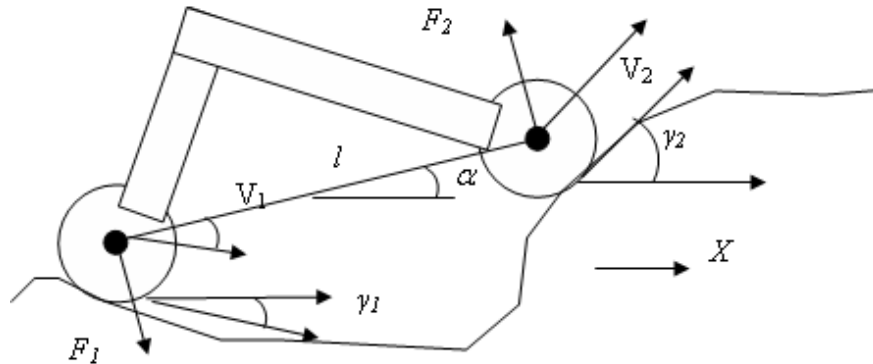

Figure 2 Planar two wheeled system in rough terrain [10]

For this system, the following kinematic equations can be written:[10]

$$v_1 \cos(\gamma_1 - \alpha) = v_2 \cos(\gamma_2 - \alpha) \quad (1)$$

$$v_2 \sin(\gamma_2 - \alpha) - v_1 \sin(\gamma_1 - \alpha) = l \dot{\alpha} \quad (2)$$

Equation (1) represents the constraint that the wheel center distance  $l$  does not change. The validity of this assumption will be examined later. Equation (2) is a rigid body kinematic relation between the velocities of the wheel centers and the vehicle pitch rate  $\dot{\alpha}$ .

Combining Equations (1) and (2) results in:[2]

$$\left\{ \frac{v_2}{v_1} \sin(\gamma_2 - \alpha) + \sin(\gamma_1 - \alpha) \right\} \cos(\gamma_2 - \alpha) = \frac{l \dot{\alpha}}{v_1} \cos(\gamma_2 - \alpha) \quad (3)$$

### Model Dynamic Force and Steering Angle With Axis [10]

Mobile robot has 3 direction motion according 3 kind of axis mobile robot has been shown in Figure 3. Longitudinal direction describes the direction of movement of the mobile robot forward. This direction can be explained in two ways. The first way is related to the mobile robot itself. The second way is related to a particular point of reference.

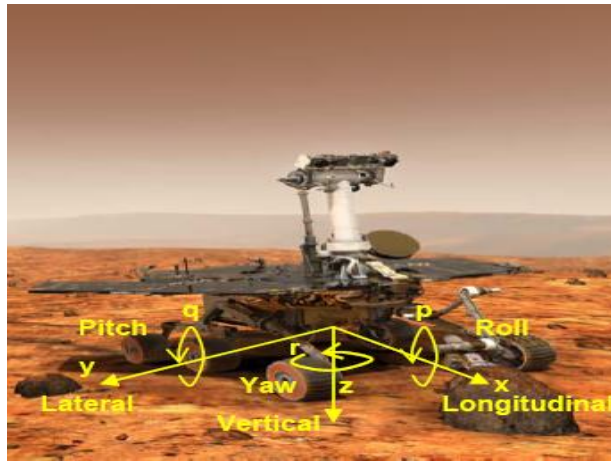

Figure 3 Model Dynamics Mobile Robot Axis [9]

1. Axis x:

Axis x shows forward direction or longitudinal direction, according of this axis mobile robot can experience a rolling motion with a central rotation in axis x.

2. Axis y:

Axis y shows lateral direction or sideway direction, positive when direction shows a right side of driver, negative when direction shows a left side of driver. Mobile robot can experience pitch motion with a central rotation in axis y.

3. Axis z:

Axis z shows vertical direction or downstairs direction of mobile robot. Mobile robot can experience a yaw motion with central rotation in axis z.

### Tire Modeling and Deviation Axis [2]

Longitudinal direction explain forward direction of mobile robot. There are two different ways of looking at the lateral direction. The first way with respect to the vehicle. The second way with respect to a fixed reference point shown in figure 4.

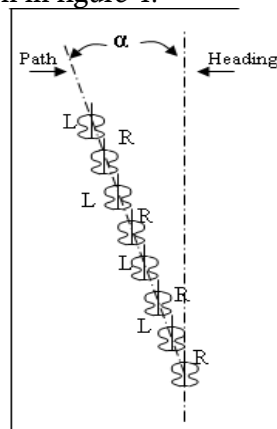

Figure 4. Walking Analogy to Tire Slip Angle [10]

Lateral direction respective to sideways direction moving. Again, there are two way of looking at the lateral direction. The first way with respect to the vehicle. The second way with respect to fixed reference point. Walking analogy explains wheel slip angle that displace to sideways because influence of lateral force in figure 4. The foot is displaced laterally due to the presence of lateral force.

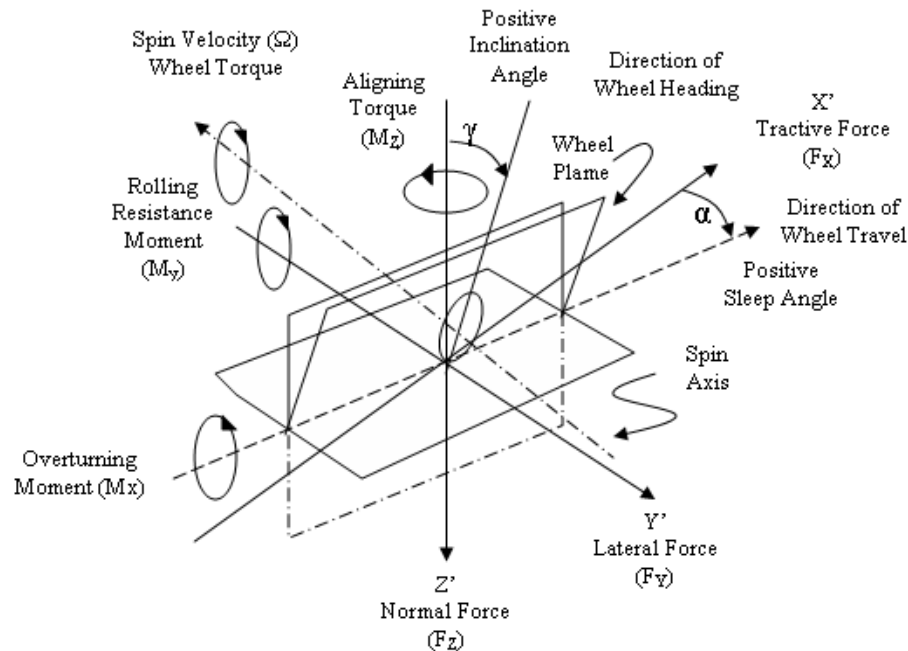

Figure. 5 Deviation axis system when mobile robot is running [10]

Figure 5 explain deviation axis system that can used to modeling of dynamic mobile robot body and wheels, that so shows forces and moments that applied to wheel and the other parameter such as slip angle and direction angle. Figure 5 shows the standard tire axis system that is commonly used in tire modeling.

### Body Slip Angle [2]

Body slip angle is the angle between X-axis and the velocity vector that represents the instantaneous vehicle velocity at that point along the path, as shown in figure 6. Figure 6 explain about schema of front wheel that can deviated.

Attempting to encapsulate all the movements of a mobile robot into a bunch of equations can be difficult. Although adding a number of elements to the model can increase the accuracy of the model, the computation time is substantially increased.

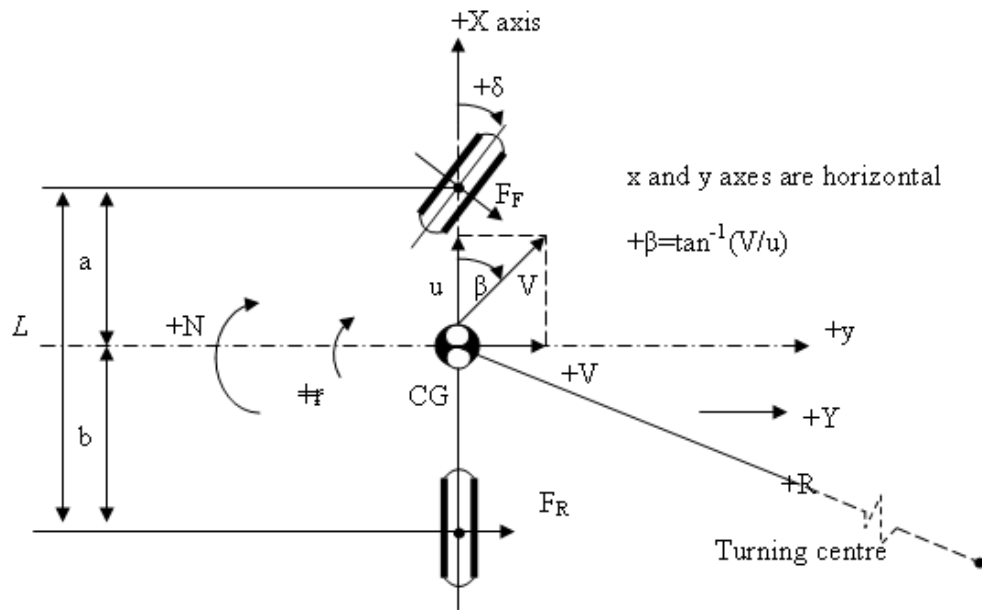

Figure 6 Schema Deviation of Front Wheel [10]

**Equation Motion Mobile Robot [10]**

Second Newton formulation for circle motion:

$$I \ddot{\theta} = T$$

Equation model dynamic motion mobile robot

$$I \ddot{\theta} = aP_f \delta + bF_{\xi f} - bF_{\xi r} \tag{11}$$

$$m(\dot{V}_\xi + V_\eta \dot{\theta}) = P_f \delta + F_{\xi f} + F_{\xi r} \tag{12}$$

$$m(\dot{V}_\eta + V_\xi \dot{\theta}) = P_f + P_r + F_{\xi f} \delta \tag{13}$$

Lateral and longitudinal velocity equation that respect with coordinate axis xyz is follow as:

$$\dot{x} = -V_\xi \sin \theta + V_\eta \cos \theta \tag{14}$$

$$\dot{y} = V_\xi \cos \theta + V_\eta \sin \theta \tag{15}$$

Longitudinal Force front wheel is shown in figure 7.

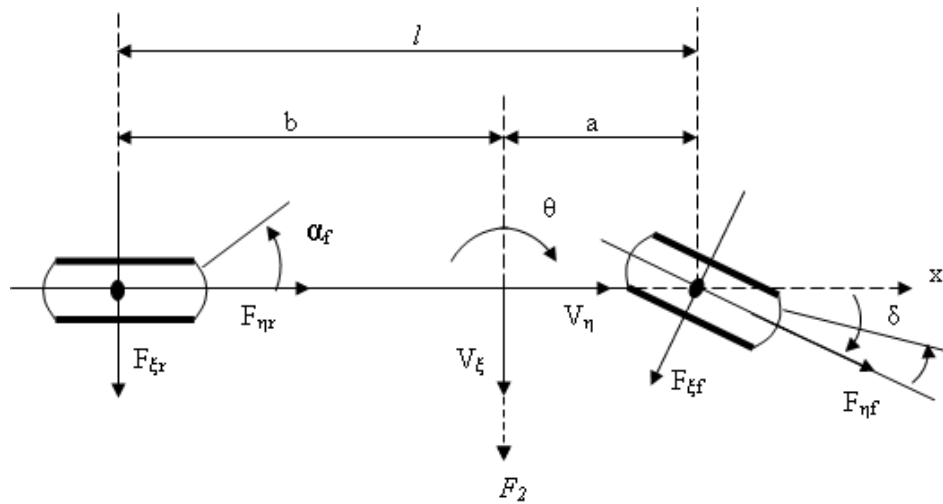
Figure 7 Longitudinal Force  $P_f$  paralel with axis  $x$  [10]

With :

$F_{\zeta f}$  = lateral force front wheel

$F_{\zeta r}$  = lateral force rear wheel

$a$  = distance between central point gravity and central point front wheels

$b$  = distance between central point gravity and central point rear wheels

$m$  = mass model mobile robot

$I$  = inertia *yaw* moving mobile robot

$P_f$  = longitudinal force front wheel

$P_r$  = longitudinal force rear wheel

$V_\eta$  = longitudinal velocity

$V_\xi$  = lateral velocity

$x$  = axis longitudinal position

$y$  = axis lateral position

$\delta$  = axis wheel deviation

$\eta$  = axis longitudinal

$\theta$  = yaw angle

$\xi$  = lateral angle

### Equation Front Wheel Slip Angle [10]

The front wheel slip angle is a function of the steering angle, the longitudinal and lateral velocity vectors, and the component of the lateral velocity caused by the yaw motion, governed by the equation.

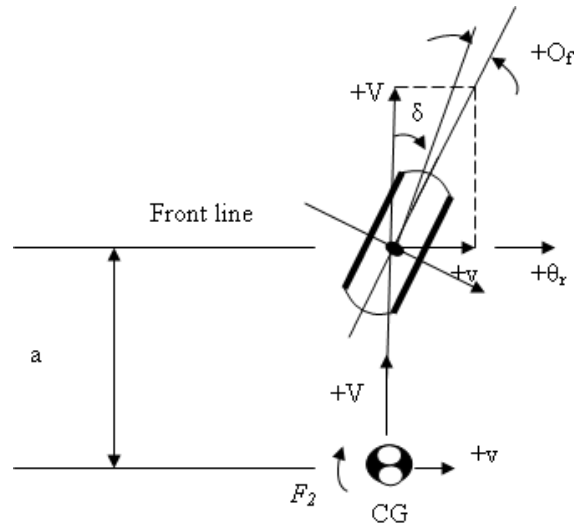

Figure 8 Schema Front Wheel Slip [10]

Vektor longitudinal and lateral velocity and lateral velocity component is arrange by equation:

$$\alpha_f = \delta - \frac{(a \dot{\theta} + V_\xi)}{V_\eta} \tag{16}$$

Schema Front Wheel Slip is shown in figure 8.

**Equation Rear Wheel Slip Angle [10]**

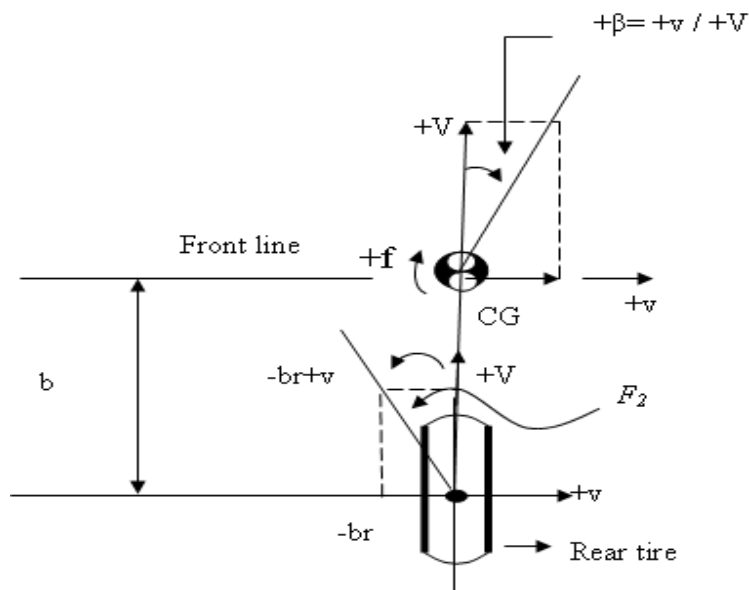

Figure 9 Schema Rear Wheel Slip [10]



Vector longitudinal and lateral velocity and lateral velocity component is arrange by equation:

$$\alpha_r = \frac{\left( b \dot{\theta} - V_{\xi} \right)}{V_{\eta}} \quad (17)$$

Schema Rear Wheel Slip is shown in figure 9.

### Force (Traction and Brake) longitudinal

Maximum traction force for mobile robot is calculated as the following:

$$F_{x \max, t} = \frac{\mu \frac{Wb}{1}}{1 + \mu \frac{h}{1}} \quad (18)$$

Maximum braking force for each suspension of mobile robot is calculated as the following:

$$F_{x \max, b} = \mu \frac{W}{l} (a + \mu h) \quad (19)$$

With

$F_{x \max, t}$  = maximum traction force

$F_{x \max, b}$  = maximum braking force

$\mu$  = friction coefficient

$W$  = weight of *mobile robot*

$l$  = Distance between central point  
front wheel to central point rear  
wheel

$h$  = Distance high between central  
gravity to ground 30 cm [9].

### Model Disturbance Ascent of Mobile Robot

On the hillside terrain the mobile robotic experiences disturbances in the form of maximum traction force and gravity. So that the force acting on the mobile robot. The forces that occur when the mobile robot experiences incline disturbances are as follows:

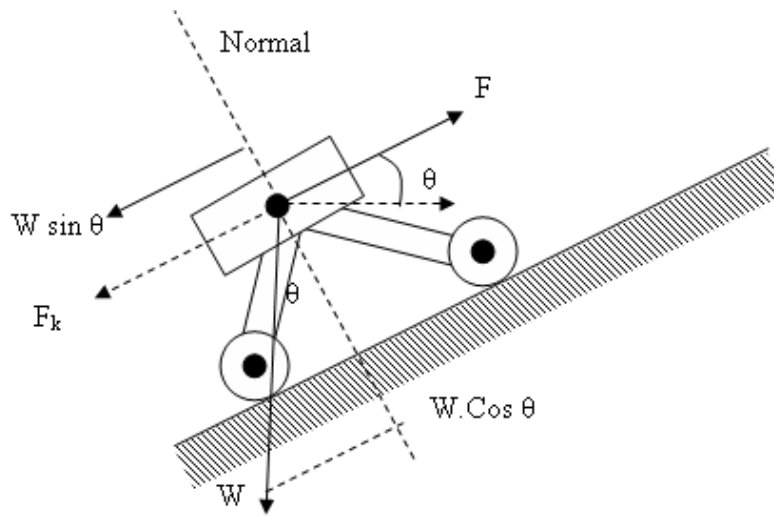

Figure 10 Ascent Terrain to Mobile Robot

Figure 10 explain mobile robot has disturbance such as friction force or maximum traction force in mobile robot, and weight force. So the force has worked to mobile robot is calculated as following:

$$\begin{aligned} \sum F &= m.a \\ F - F_k - W.\sin \theta &= m.a \\ F - F_{x_{max,t}} - mg.\sin \theta &= m.a \\ F - \frac{\mu Wb}{1 + \mu \frac{h}{1}} - m.g.\sin \theta &= m.a \end{aligned} \quad (20)$$

With

$F$  = Force rear wheel of mobile robot

$F_{x_{max,t}}$  = Maximum traction force (friction force of *mobile robot*)

So the equation will change to be:  
(Longitudinal axis)

$$m.a = \sum F$$

$$m(\dot{V}_\eta + V_\xi \dot{\theta}) = P_f + P_r + F_{\xi f} \delta - F_{x_{\max,t}} - W \cdot \sin \theta \quad (21)$$

$$m(\dot{V}_\eta + V_\xi \dot{\theta}) = P_f + P_r + F_{\xi f} \delta - \frac{\mu \frac{Wb}{1}}{1 + \mu \frac{h}{1}} - W \cdot \sin \theta$$

### Model Disturbance Rough Terrain to Mobile Robot

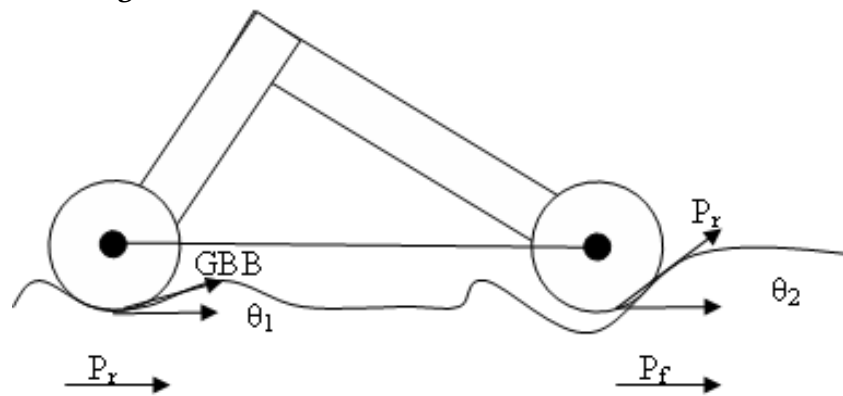

Figure 11 Rough Terrain to Mobile Robot

The force that worked to mobile robot when face rough terrain is calculated as following:

$$P_r = GBB \cdot \cos \theta_1$$

$$P_f = P_r \cdot \cos \theta_2$$

With

GBB = Force from rear wheel

$\theta_1$  = Contact Ground rear wheel angle.

$\theta_2$  = Contact Ground front wheel angle.

Rough Terrain to Mobile Robot is shown in figure 11.

### Model Dynamic Friction

Models in mobile robots actually have dynamic friction and are not static. If the friction is static, then what happens is that if the mobile robot is given a constant force continuously, the acceleration of the mobile robot is also constant, causing the mobile robot's speed to continue to rise until it is not even if the friction force has been applied. In fact, a model like this is impossible, because in reality the friction in the mobile robot will continue to increase along with the increasing speed of the mobile robot. The relationship between speed and friction force on a mobile robot can be determined using the classical friction model as follows:

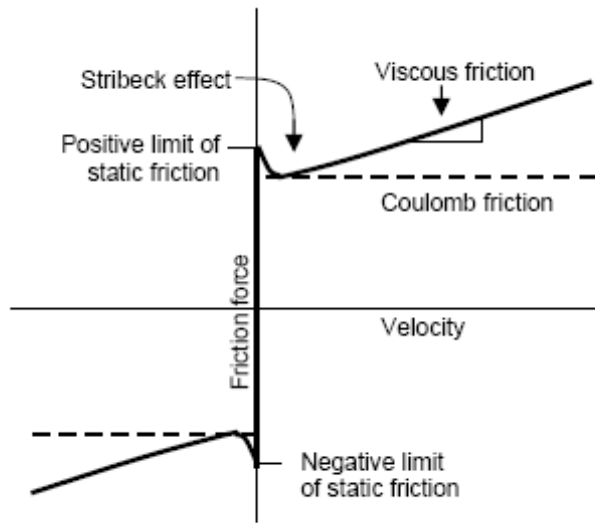

Figure 12 Relation dynamic friction and velocity

Relation between velocity with the friction force in mobile robot can show to classical friction model in above is shown in figure 12. So that if the speed of the mobile robot goes to infinity, then the friction force of the mobile robot also rises to infinity, so that at a certain point the speed will be constant. The friction force in this mobile robot can come from the driving force such as a DC motor, servo motor or others, but friction also occurs when the mobile robot moves and interacts with its environment.

Model dynamic friction force of mobile robot is computed as following:

$$F_k = \frac{\mu \frac{Wb}{1}}{1 + \mu \frac{h}{1}} \cdot V_\eta \tag{22}$$

So the equation will change to be:

$$m \cdot a = \sum F$$

$$m(\dot{V}_\eta + V_\xi \dot{\theta}) = P_f + P_r + F_{\text{eff}} \delta - \frac{\mu \frac{Wb}{1}}{1 + \mu \frac{h}{1}} \cdot V_\eta - W \cdot \sin \theta \tag{23}$$

And then:

$$\begin{aligned}
I \ddot{\theta} &= aP_f \delta + bF_{\xi f} - bF_{\xi r} \\
m(\dot{V}_\xi + V_\eta \dot{\theta}) &= P_f \delta + F_{\xi f} + F_{\xi r} \\
m(\dot{V}_\eta + V_\xi \dot{\theta}) &= P_f + P_r + F_{\xi f} \delta - \frac{\mu \frac{Wb}{l}}{1 + \mu \frac{n}{l}} V_\eta - W \cdot \sin \theta
\end{aligned} \tag{24}$$

## DESIGN STATE SPACE EQUATION, SIMULATION MODEL AND TEST

### Solution for Dynamic Model Equation of Motion Mobile Robot

Model dynamic motion mobile robot has 5 variable input and 7 variable state output, so this model include to model multivariable system. Dynamic model of mobile robot consist of seven differential equation. And all of them is nonlinear system.

#### Contribution Results

Design recursive equation for modeling:

State  $x_1$  is yaw velocity:

From equation (24), can be modify to be:

$$\begin{aligned}
\ddot{\theta} &= \frac{(a P_f \delta + b F_{\xi f} - b F_{\xi r})}{I} - \dot{\theta} \\
\dot{x}_1 &= \frac{(a P_f \delta + b F_{\xi f} - b F_{\xi r})}{I} - x_1
\end{aligned} \tag{25}$$

State  $x_2$  is lateral velocity:

From equation (24), can be modify to be:

$$\begin{aligned}
\dot{V}_\xi &= \frac{(P_f \delta + F_{\xi f} + F_{\xi r})}{m} - V_\eta \dot{\theta} \\
\dot{x}_2 &= \frac{(P_f \delta + F_{\xi f} + F_{\xi r})}{m} - x_3 x_1
\end{aligned} \tag{26}$$

State  $x_3$  is longitudinal velocity:

From equation (24), can be modify to be :

$$\dot{V}_\eta = \frac{\left( P_f + P_r + F_{\xi f} \delta - x_3 \frac{\mu \frac{Wb}{l}}{1 + \mu \frac{n}{l}} - mg \sin \beta \right)}{m} - V_\xi \dot{\theta}$$

$$\dot{x}_3 = \frac{\left( P_f + P_r + F_{\xi r} \delta - x_3 \frac{\mu \frac{Wb}{l}}{l + \mu \frac{n}{l}} - mg \sin \beta \right)}{m} - x_2 x_1 \quad (27)$$

State  $x_4$  is position  $x$ :

From equation (14), can be modify to be:

$$\begin{aligned} \dot{x} &= -V_{\xi} \sin \theta + V_{\eta} \cos \theta \\ \dot{x}_4 &= -x_2 \sin x_7 + x_3 \cos x_7 \end{aligned} \quad (28)$$

State  $x_5$  is position  $y$ :

From equation (15), can be modify to be :

$$\begin{aligned} \dot{y} &= V_{\xi} \cos \theta + V_{\eta} \sin \theta \\ \dot{x}_5 &= x_2 \cos x_7 + x_3 \sin x_7 \end{aligned} \quad (29)$$

State  $x_6$  is pitch angle:

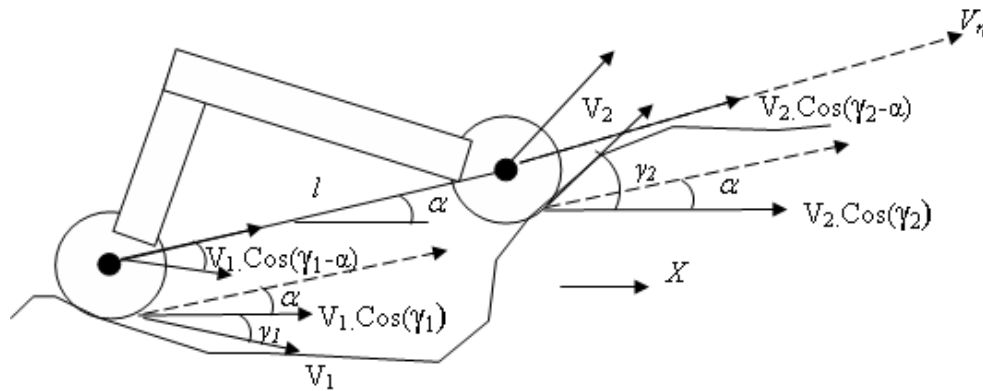

Figure 13 Kinematics and pitch angle in terrain

From equation (1), can be modify to be:

$$\begin{aligned} v_1 \cos(\gamma_1 - \alpha) &= v_2 \cos(\gamma_2 - \alpha) = V_{\eta} \\ V_1 &= \frac{V_{\eta}}{\cos(\gamma_1 - \alpha)} \quad ; \quad V_2 = \frac{V_{\eta}}{\cos(\gamma_2 - \alpha)} \end{aligned} \quad (30)$$

From equation (2), can be modify to be:

$$v_2 \sin(\gamma_2 - \alpha) - v_1 \sin(\gamma_1 - \alpha) = l \dot{\alpha}$$

Because  $\alpha = \beta$  and  $V_\eta = x_3$ , then

$$\dot{x}_6 = \frac{\left\{ \frac{x_3}{\cos(\gamma_2 - \beta)} \right\} \sin(\gamma_2 - \beta) - \left\{ \frac{x_3}{\cos(\gamma_1 - \beta)} \right\} \sin(\gamma_1 - \beta)}{l}$$

If *wheel contact ground angle* rear or front of mobile robot more than  $\alpha$ , then speed longitudinal velocity mobile robot will be increase. If *wheel contact ground angle* rear or front of mobile robot less than  $\alpha$ , then speed longitudinal velocity of mobile robot will be decrease.

So that with wheel contact ground angle ( $\gamma_1$  dan  $\gamma_2$ ), if wheel contact ground angle more than  $\alpha$  angle, then angle of ( $\gamma_1$  dan  $\gamma_2$ ) is positive, if wheel contact ground angle less than  $\alpha$  angle, then angle of ( $\gamma_1$  dan  $\gamma_2$ ) is negative. Kinematics and pitch angle in terrain is shown in figure 13.

State  $x_7$  is yaw angle:

$$\dot{x}_7 = x_1 \quad (31)$$

These seven State Space parameters will be tested on 3 mobile robots with different weight parameters and with incline disturbances, rough terrain and a combination of both in the simulation using MATLAB Simulink Programming.

### 3. Results and Discussion

#### Result Model Motion Mobile Robot:

This is nonlinear multivariable system of motion mobile robot:

$$\begin{aligned} \dot{x}_1 &= \frac{(a P_f \delta + b F_{\xi f} - b F_{\xi r})}{I} - x_1 \\ \dot{x}_2 &= \frac{(P_f \delta + F_{\xi f} + F_{\xi r})}{m} - x_3 x_1 \quad (25) \\ \dot{x}_3 &= \frac{\left( P_f + P_r + F_{\xi r} \delta - x_3 \frac{\mu \frac{Wb}{l}}{l + \mu \frac{n}{l}} - mg \sin \beta \right)}{m} - x_2 x_1 \\ \dot{x}_4 &= -x_2 \sin x_7 + x_3 \cos x_7 \\ \dot{x}_5 &= x_2 \cos x_7 + x_3 \sin x_7 \\ \dot{x}_6 &= \frac{\left\{ \frac{x_3}{\cos(\gamma_2 - \beta)} \right\} \sin(\gamma_2 - \beta) - \left\{ \frac{x_3}{\cos(\gamma_1 - \beta)} \right\} \sin(\gamma_1 - \beta)}{l} \\ \dot{x}_7 &= x_1 \end{aligned}$$

Variable input is :

- $F_{\xi f}$  = lateral force front wheel
- $F_{\xi r}$  = lateral force rear wheel
- $P_f$  = longitudinal force front wheels
- $P_r$  = longitudinal force rear wheels
- $\delta$  = Steering angle mobile robot

Variables Disturbance is :

- $\beta$  = ascent angle
- $\gamma_1$  = contact angle ground rear wheel
- $\gamma_2$  = contact angle ground front wheel

Variable Output is :

- $x_1$  = yaw velocity
- $x_2$  = lateral velocity
- $x_3$  = longitudinal velocity
- $x_4$  = position x
- $x_5$  = position y
- $x_6$  = pitch angle
- $x_7$  = yaw angle



Model Nonlinear Motion Mobile Robot:

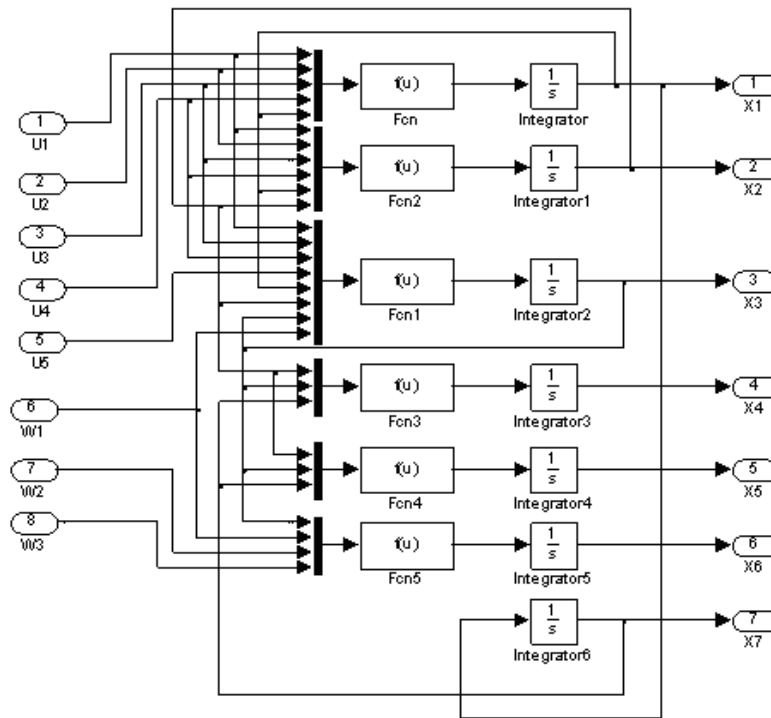

Figure 14 Model Nonlinear Mobile Robot

Model Nonlinear Mobile Robot is shown in figure 14.

### **Simulation Mobile Robot**

Parameters of mobile robot for simulation:

Tabel. 1 Parameter Mobil Robot

Parameter Mobile Robot	ISO	Symbol	Model Mobile Robot		
			Model A	Model B	Model C
Massa	Kg	m	35.74	35.74	40.42
Inertia	Kg.m <sup>2</sup>	I	42.3	45.2	50
Distance Between Central point Front wheel to Central point Gravity	m	a	0.33	0.42	0.53
Distance Between Central point Rear wheel to Central point Gravity	m	b	0.48	0.57	0.64
High Between Central Gravity to Ground	m	h	0.31	0.35	0.42
Diameter Front Wheel And Rear Wheel	m	d	0.15	0.155	0.163

### Sample Design Model

(Mobile Robot A) Design from DEE Simulink

$$\begin{aligned}\dot{x}_1 &= -(x(1)) + (0.33 \cdot u(4) \cdot u(1) + 0.48 \cdot (u(2) - u(3))) / 42.3 \\ \dot{x}_2 &= -(x(3) \cdot x(1)) + (u(4) \cdot u(1) + u(2) + u(3)) / 30.10 \\ \dot{x}_3 &= -(x(2) \cdot x(1)) + (u(3) \cdot u(1) + u(4) + u(5) - \\ &\quad u(6) \cdot x(3) - u(7)) / 30.10 \\ \dot{x}_4 &= -x(2) \cdot \sin(x(6)) + x(3) \cdot \cos(x(6)) \\ \dot{x}_5 &= x(2) \cdot \cos(x(6)) + x(3) \cdot \cos(x(6)) \\ \dot{x}_6 &= ((x(3) \cdot \cos(u(8)) / \cos(u(9) - u(8))) \cdot \sin(u(9) - u(8)) - \\ &\quad (x(3) \cdot \cos(u(8)) / \cos(u(9) - u(8))) \cdot \sin(u(10) - u(8))) / 0.81 \\ \dot{x}_7 &= x(1)\end{aligned}$$

### State Space Nonlinear Mobile Robot A

$$\begin{aligned}\dot{x}_1 &= 7.8014 \cdot u_4 \cdot u_1 + 11.3475 \cdot u_2 - 11.3475 \cdot u_3 - x_1 \\ \dot{x}_2 &= 0.0332 \cdot u_4 \cdot u_1 + 0.0332 \cdot u_2 + 0.0332 \cdot u_3 - x_3 \cdot x_1 \\ \dot{x}_3 &= 0.0332 \cdot u_4 + 0.0332 \cdot u_5 + 0.0332 \cdot u_3 \cdot u_1 - 2.8998 \cdot x_3 - 9.8 \cdot \sin(\beta) - x_2 \cdot x_1 \\ \dot{x}_4 &= -x_2 \cdot \sin(x_7) + x_3 \cdot \cos(x_7) \\ \dot{x}_5 &= x_2 \cdot \cos(x_7) + x_3 \cdot \cos(x_7) \\ \dot{x}_6 &= 1.2346 \cdot x_3 \cdot \tan(\gamma_2 - \beta) - 1.2346 \cdot x_3 \cdot \tan(\gamma_1 - \beta) \\ \dot{x}_7 &= x_1\end{aligned}$$

### State Space Nonlinear Mobile Robot B

$$\begin{aligned}\dot{x}_1 &= 9.2920 \cdot u_4 \cdot u_1 + 12.6106 \cdot u_2 - 12.6106 \cdot u_3 - x_1 \\ \dot{x}_2 &= 0.028 \cdot u_4 \cdot u_1 + 0.028 \cdot u_2 + 0.028 \cdot u_3 - x_3 \cdot x_1 \\ \dot{x}_3 &= 0.028 \cdot u_4 + 0.028 \cdot u_5 + 0.028 \cdot u_3 \cdot u_1 - 2.418 \cdot x_3 - 9.8 \cdot \sin(\beta) - x_2 \cdot x_1 \\ \dot{x}_4 &= -x_2 \cdot \sin(x_7) + x_3 \cdot \cos(x_7) \\ \dot{x}_5 &= x_2 \cdot \cos(x_7) + x_3 \cdot \cos(x_7) \\ \dot{x}_6 &= 1.0101 \cdot x_3 \cdot \tan(\gamma_2 - \beta) - 1.0101 \cdot x_3 \cdot \tan(\gamma_1 - \beta) \\ \dot{x}_7 &= x_1\end{aligned}$$

### State Space Nonlinear Mobile Robot C

$$\dot{x}_1 = 10.6.u_4.u_1 + 12.8.u_2 - 12.8.u_3 - x_1$$

$$\dot{x}_2 = 0.0247.u_4.u_1 + 0.0247.u_2 + 0.0247.u_3 - x_3.x_1$$

$$\dot{x}_3 = 0.0247.u_4 + 0.0247.u_5 + 0.0247.u_3.u_1 - 1.9862.x_3 - 9.8.\sin(\beta) - x_2.x_1$$

$$\dot{x}_4 = -x_2.\sin(x_7) + x_3.\cos(x_7)$$

$$\dot{x}_5 = x_2.\cos(x_7) + x_3.\cos(x_7)$$

$$\dot{x}_6 = 0.8547.x_3.\tan(\gamma_2 - \beta) - 0.8547.x_3.\tan(\gamma_1 - \beta)$$

$$\dot{x}_7 = x_1$$

### Experiment Nonlinear Model Mobile Robot in Simulation using Simulink

Simulation using Simulink of MATLAB, and report from test modeling mobile robot as following. (Force in Rear Wheel is 200 N,  $\mu$  is 0.5)

#### 1. Simulation without Disturbance

Mobile Robot A, B, C:

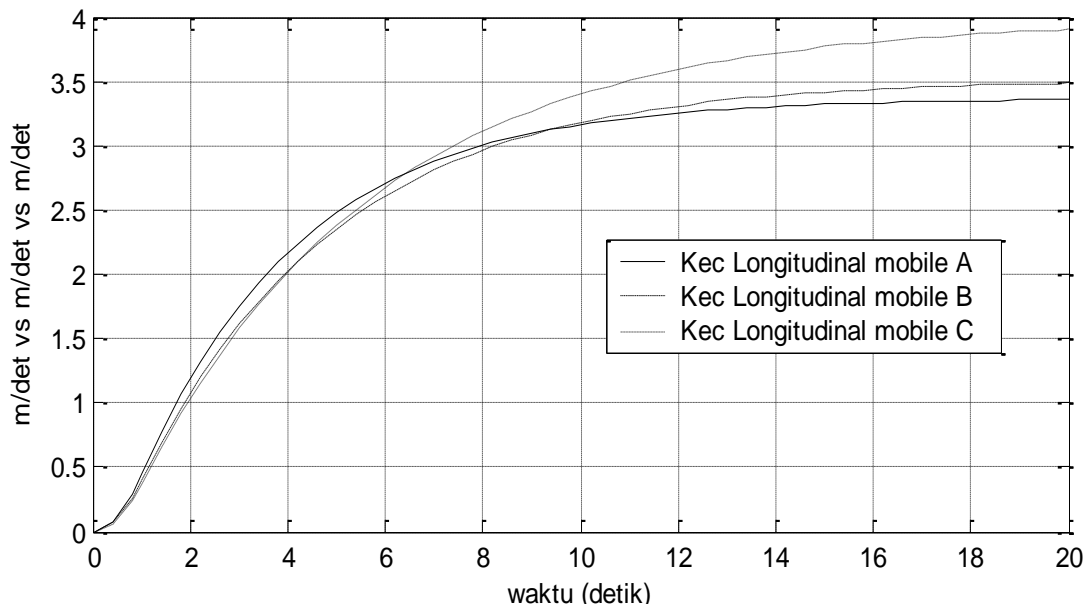

Figure 15 Longitudinal Velocity without Disturbance

Longitudinal Velocity without Disturbance is shown in figure 15.

#### 2. Simulation with Disturbance Ascent Angle $30^\circ = 0.5236$ rad

Mobile Robot A, B, C:

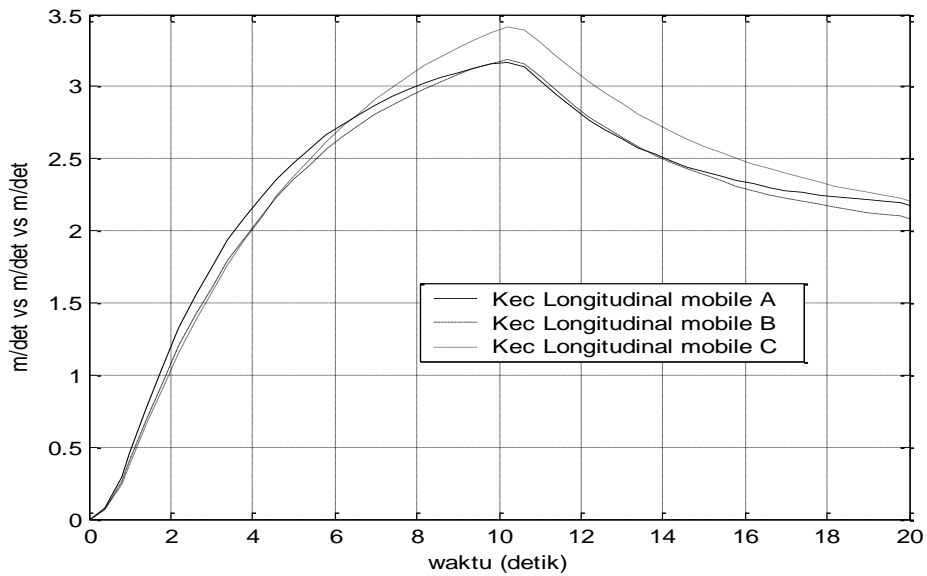

Figure 16 Longitudinal Velocity with Disturbance (Ascent Angle  $30^\circ = 0.5236$  rad)

Longitudinal Velocity with Disturbance (Ascent Angle  $30^\circ = 0.5236$  rad) is shown in figure 16.

3. Simulation with Disturbance Ascent Angle  $45^\circ = 0.7854$  rad  
Mobile Robot A, B, C

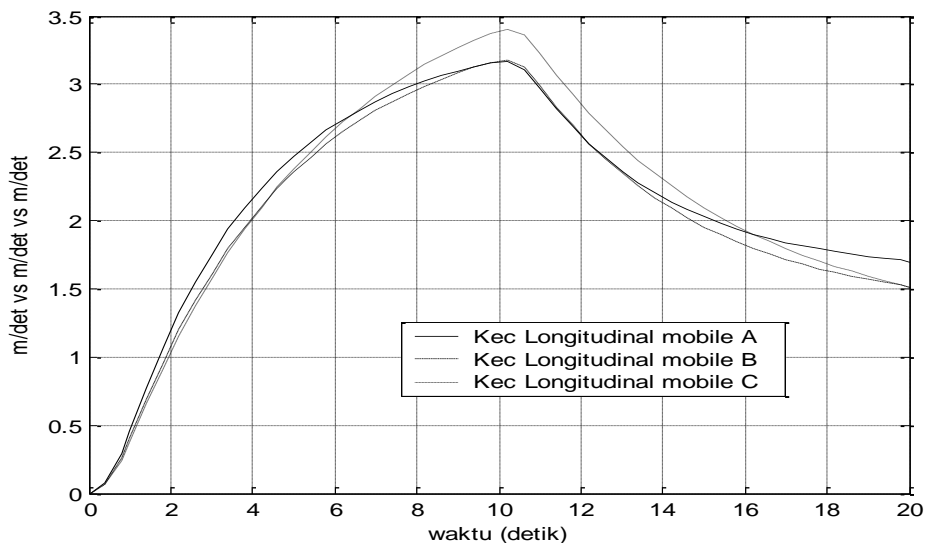

Figure 17 Longitudinal Velocity with Disturbance (Ascent Angle  $45^\circ = 0.7854$  rad)

Longitudinal Velocity with Disturbance (Ascent Angle  $45^\circ = 0.7854$  rad) is shown in figure 17.

4. Simulation with Disturbance Rough Terrain *contact angle* =  $\pm 28.6479^\circ = \pm 0.5$  rad

Mobile Robot A, B, C:

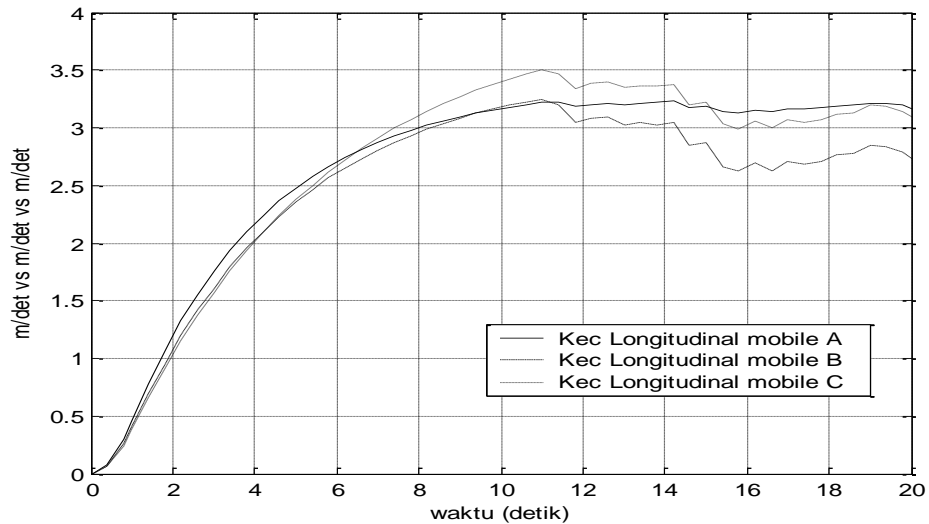

Figure 18 Longitudinal Velocity with Disturbance  
Rough Terrain  $contact\ angle = \pm 28.6479^\circ = \pm 0.5\ rad$

Longitudinal Velocity with Disturbance Rough Terrain  $contact\ angle = \pm 28.6479^\circ = \pm 0.5\ rad$  is shown in figure 18 and  $contact\ angle = \pm 68.7549^\circ = \pm 1.2\ rad$  in figure 19.

5. Simulation with Disturbance Rough Terrain  $contact\ angle = \pm 68.7549^\circ = \pm 1.2\ rad$   
Mobile Robot A, B, C:

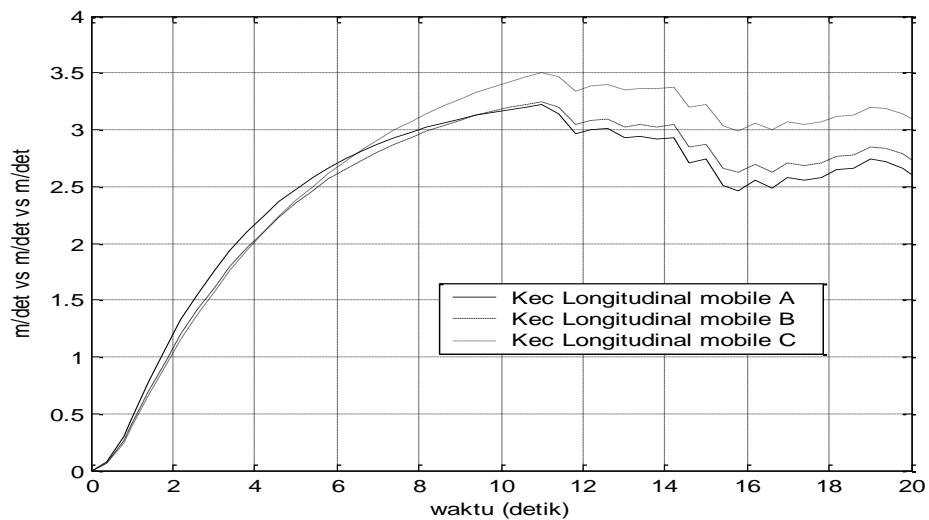

Figure 19 Longitudinal Velocity with Disturbance  
Rough Terrain  $contact\ angle = \pm 68.7549^\circ = \pm 1.2\ rad$

6. Simulation with Combine Disturbance

Ascent Angle  $30^\circ = 0.5236$  rad and Rough Terrain =  $\pm 28.6479^\circ = \pm 0.5$  rad  
Mobile Robot A, B, C:

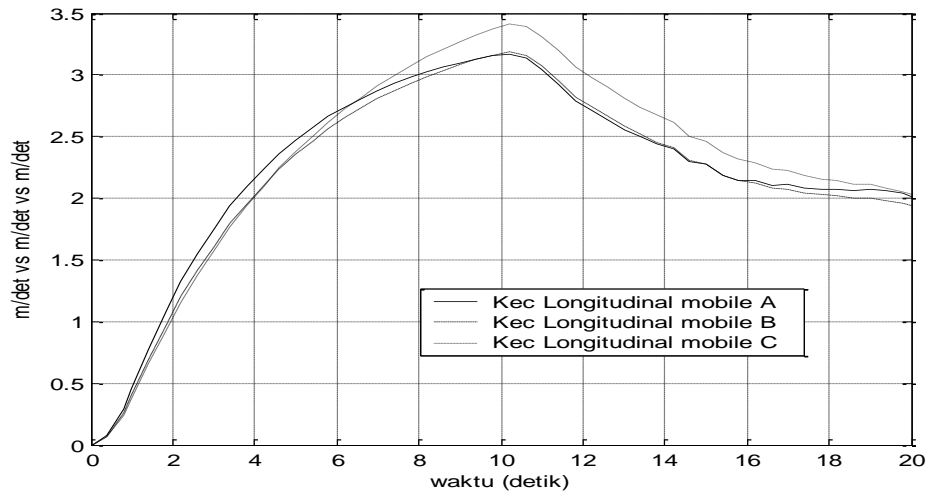

Figure 20 Longitudinal Velocity with Disturbance Ascent Angle  $30^\circ = 0.5236$  rad  
And contact angle =  $\pm 28.6479^\circ = \pm 0.5$  rad

Longitudinal Velocity with Disturbance (Ascent Angle  $30^\circ = 0.5236$  rad and contact angle =  $\pm 28.6479^\circ = \pm 0.5$  rad) is shown in figure 20 and (Ascent Angle  $30^\circ = 0.5236$  rad and contact angle =  $\pm 45.8366^\circ = \pm 0.8$  rad) is shown in figure 21.

#### 7. Simulation with Combine Disturbance

Ascent Angle  $30^\circ = 0.5236$  rad and Rough Terrain =  $\pm 45.8366^\circ = \pm 0.8$  rad  
Mobile Robot A, B, C:

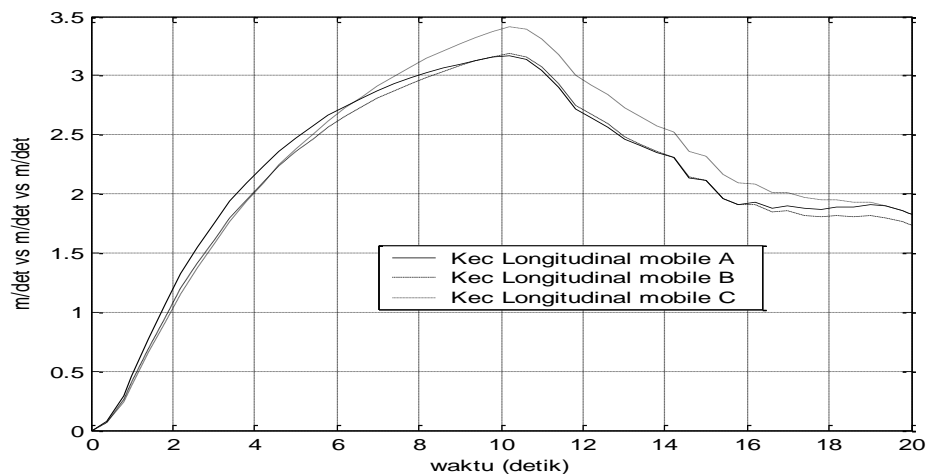

Figure 21 Longitudinal Velocity with Disturbance Ascent Angle  $30^\circ = 0.5236$  rad  
And contact angle =  $\pm 45.8366^\circ = \pm 0.8$  rad

Table. 1 Test Result Model Mobile Robot A

Mobile Robot A Force in Rear Wheel is 200 N, $\mu$ is 0,5 Disturbance from t = 11s until t = 20s Max traction force is 8,9064 Newton Diameter wheel is 0,15m or 15cm		Approach Convergent Velocity in t=10s (rad/s or m/s)	The Velocity is Reduced (rad/s or m/s)	Distance Between t=0s to t=20s (rad or m)
	30 <sup>0</sup>	40.6125 rad/s or 3.1327 m/s	29.2586 rad/s or 2.1740 m/s	619.4985 rad or 46.4624 m
Disturbance Ascent Terrain	45 <sup>0</sup>	42.1928 rad/s or 3.1645 m/s	22.5863 rad/s or 1.6940 m/s	575.6835 rad or 43.1763 m
Disturbance Rough Terrain	$\pm 0.5$ rad	42.6409 rad/s or 3.1981 m/s	Random	709.1563 rad or 53.1867 m
(Rear and Front Wheel)	$\pm 1.2$ rad	42.6409 rad/s or 3.1981 m/s	Random	657.4013 rad or 49.3051 m
Combine Disturbance In Ascent Angle 30 <sup>0</sup> And Contact Ground	$\pm 0.5$ rad	42.2469 rad/s or 3.1685 m/s	26.7565 rad/s or 2.0067 m/s	604.2141 rad or 45.3161 m
	$\pm 0.8$ rad	42.2469 rad/s or 3.1685 m/s	24.3681 rad/s or 1.8276 m/s	586.4518 rad or 43.9839 m
Without Disturbance, The Velocity from t=0s to t=20s		44.7708 rad/s or 3.3578 m/s	44.7708 rad/s or 3.3578 m/s	724.4659 rad or 54.3349 m

Table. 2 Test Result Model Mobile Robot B

Mobile Robot B Force in Rear Wheel is 200 N, $\mu$ is 0,5 Disturbance from t = 11s until t = 20s Max traction force is 8,8182 Newton Diameter wheel is 0,155m or 15,5cm		Approach Convergent Velocity in t=10s (rad/s or m/s)	The Velocity is Reduced (rad/s or m/s)	Distance Between t=0s to t=20s (rad or m)
	30 <sup>0</sup>	41.0978 rad/s or 3.3578 m/s	26.8702 rad/s or 2.0824 m/s	586.0023 rad or 45.4152 m
Disturbance Ascent Terrain	45 <sup>0</sup>	41.0434 rad/s or 3.1809 m/s	19.4754 rad/s or 1.5093 m/s	537.4874 rad or 41.6553 m
Disturbance Rough Terrain	$\pm 0.5$ rad	41.5972 rad/s or 3.2238 m/s	Random	687.9295 rad or 53.3145 m
(Rear and Front Wheel)	$\pm 1.2$ rad	41.5972 rad/s or 3.2238 m/s	33.8415 rad/s or 2.6227 m/s	639.7189 rad or 49.5782 m
Combine Disturbance In Ascent Angle 30 <sup>0</sup> And Contact Ground	$\pm 0.5$ rad	41.0978 rad/s or 3.1851 m/s	24.9803 rad/s or 1.9360 m/s	573.3359 rad or 44.4335 m
	$\pm 0.8$ rad	41.0978 rad/s or 3.1851 m/s	22.3284 rad/s or 1.7304 m/s	555.2137 rad or 43.0291 m
Without Disturbance, The Velocity from t=0s to t=20s		44.9907 rad/s or 3.4868 m/s	44.9907 rad/s or 3.4868 m/s	702.1881 rad or 54.4196 m

Table. 3 Test Result Model Mobile Robot C

Mobile Robot C Force in Rear Wheel is 200 N, $\mu$ is 0,5 Disturbance from t = 11s until t = 20s Max traction force is 8,1920 Newton Diameter wheel is 0,163m or 16,3cm	Approach Convergent Velocity in t=10s (rad/s or m/s)	The Velocity is Reduced (rad/s or m/s)	Distance Between t=0s to t=20s (rad or m)
Disturbance Ascent Terrain	$30^0$ 41.6240 rad/s or 3.3578 m/s	27.1022 rad/s or 2.2088 m/s	587.7411 rad or 47.9009 m
Disturbance Rough Terrain (Rear and Front Wheel)	$45^0$ 41.8142 rad/s or 3.4079 m/s	18.5837 rad/s or 1.5146 m/s	534.2234 rad or 43.5392 m
Combine Disturbance In Ascent Angle $30^0$ And Contact Ground	$\pm 0.5$ rad 41.9782 rad/s or 3.4212 m/s	Random 36.7053 rad/s or 3.0480 m/s	701.9803 rad or 57.2114 m
	$\pm 1.2$ rad 41.9782 rad/s or 3.4212 m/s	24.8814 rad/s or 2.0278 m/s	655.0364 rad or 53.3855 m
	$\pm 0.5$ rad 41.8687 rad/s or 3.4123 m/s	22.4360 rad/s or 1.8285 m/s	573.8866 rad or 46.7718 m
	$\pm 0.8$ rad 41.8687 rad/s or 3.4123 m/s	47.8881 rad/s or 3.9029 m/s	557.7580 rad or 45.4573 m
Without Disturbance, The Velocity from t=0s to t=20s	47.8881 rad/s or 3.9029 m/s	47.8881 rad/s or 3.9029 m/s	715.8616 rad or 58.3427 m

Test result of Mobile Robot A, B and C is shown in Table 1, 2 and 3 in above.

**Analysis:** (Case Longitudinal Velocity with Ascent Angle Disturbance  $30^0 = 0.5236$  rad)

A. Mobile Robot A:

The longitudinal velocity converges, approaches the value 40.6125 rad / s then drops to 29.2586 rad / s or 3.1327 m / s and then drops to 2.1740 m / s. The deviation of the steering angle is 0. In the longitudinal position of the 20s it has passed 619.4985 rad or 46.4624 meters from the normal 54.3349 meters without interference with a wheel diameter of 0.15m or 15cm. The maximum traction force of the mobile robot is 8.9064 Newton. The normal force of the mobile robot when facing a climbing angle of  $30^0$  is 147.4900 Newton.

b. Mobile Robot B:

Longitudinal velocity towards convergence approaches the value 41.0978 rad / s then decreases to 26.8702 rad / s or 3.3578 m / s and then decreases to 2.0824 m / s. The deviation of the steering angle is 0. In the longitudinal position of the 20s it has passed 586.0023 rad or 45.4152 meters from the normal 54.3349 meters without interference with a wheel diameter of 0.155m or 15.5cm. The maximum traction force of the mobile robot is 8.8182 Newton. The normal force of the mobile robot when facing a climbing angle of  $30^0$  is 175.1260 Newton.

c. Mobile Robot C:

Longitudinal velocity towards convergence approaches the value 41.6240 rad / s then decreases to 27.1022 rad / s or 3.3578 m / s and then decreases to 2.2088 m / s. The deviation of the steering angle is 0. In the longitudinal position of the 20s it has passed 587.7411 rad or 47.9009 meters from the normal 58.3427 meters without interference with a wheel diameter of 0.163m or 16.3cm. The maximum traction force of the mobile robot is 8.9064 Newton. The normal force of the mobile robot when facing a climbing angle of  $30^0$  is 198.0580 Newton.



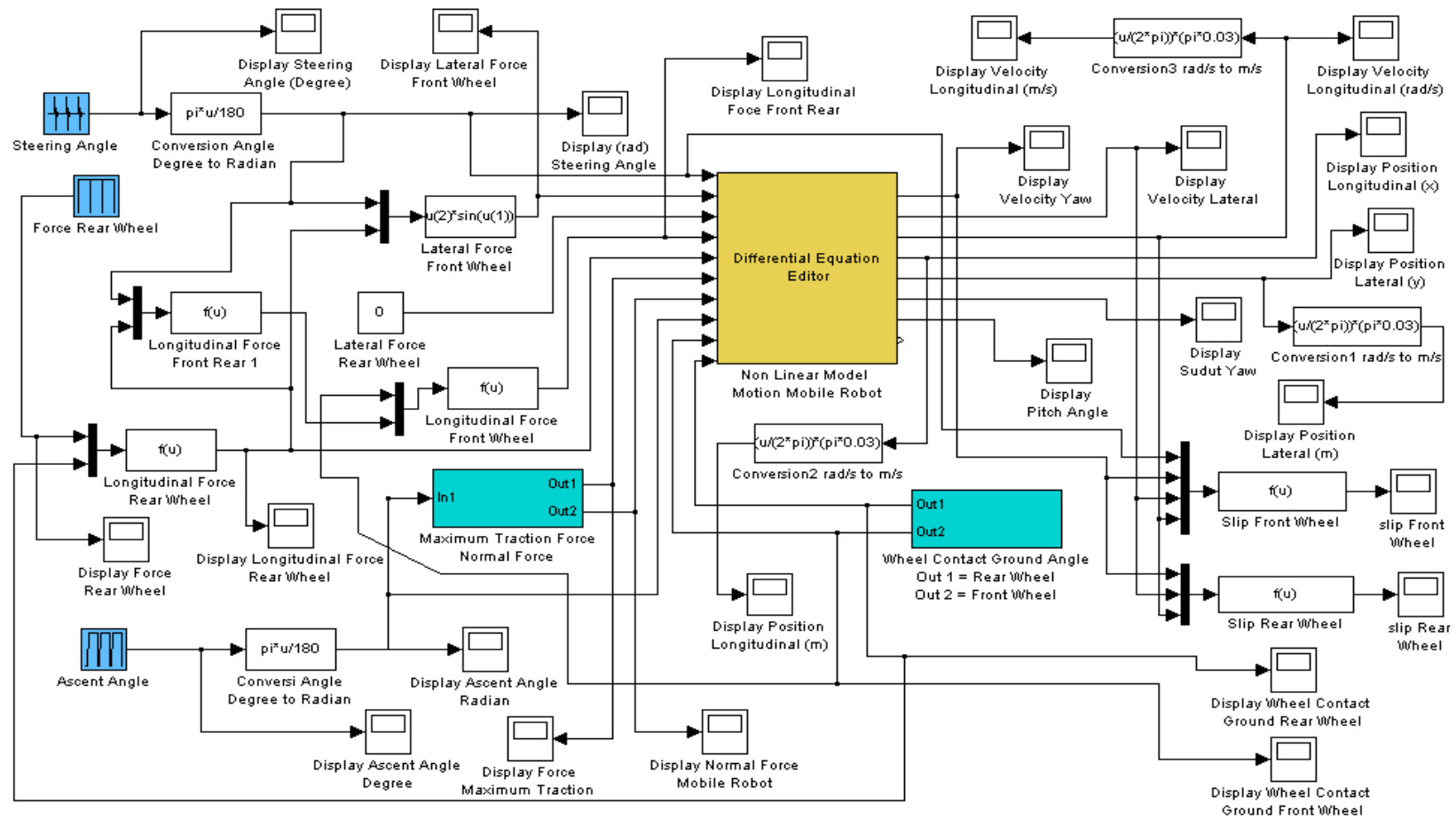

Figure 22 Plant *Mobile robot a car like vehicle* Non Linear Model Multivariable MIMO system.

8. Sample Test in Experiment Mobile Robot A.

Simulation with Disturbance Rough Terrain  $\text{contact angle} = +28.6479^\circ = \pm 0.5 \text{ rad}$

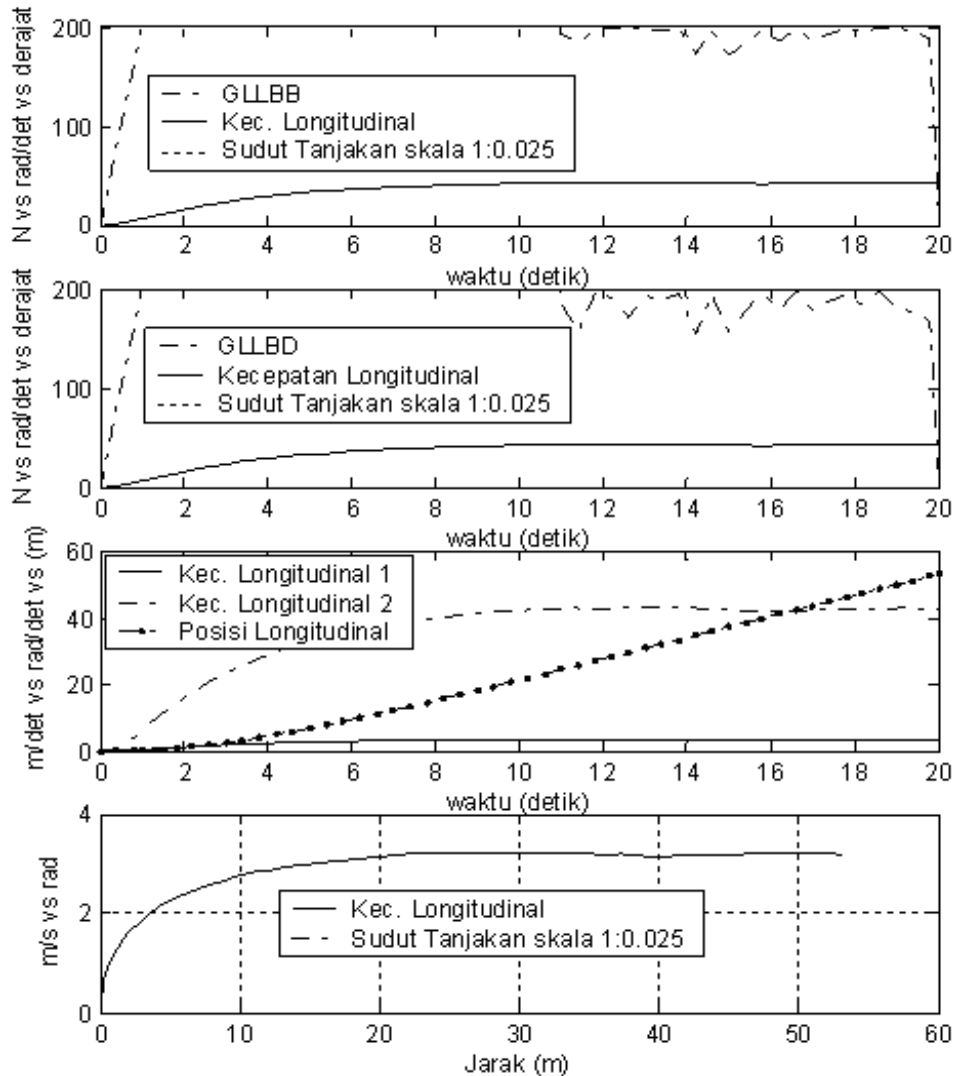

Figure 23 State Variable Output Mobil Robot A

Plant *Mobile robot a car like vehicle* Non Linear Model Multivariable MIMO system is shown in figure 22. State Variable Output Mobil Robot A is shown in figure 23. The dynamic model nonlinear motion mobile robot has characteristic where, longitudinal velocity mobile robot will increase infinity when force rear wheel is given as constant value, but because coefficient friction value increases infinity too, then longitudinal velocity mobile robot will convergent in special value. This model just for mobile robot type car like vehicle steering. Figure 15 shows that the longitudinal velocity mobile robot A without disturbance will convergent in 3.4 m/s. The longitudinal velocity mobile robot B without disturbance will convergent in 3.5 m/s. The longitudinal velocity mobile robot C without disturbance will convergent in 3.9 m/s.

#### 4. Conclusion

The Table 1, 2 and 3 of test result shows that the longitudinal velocity mobile robot A with disturbance (Ascent Terrain =  $30^0$ ) will convergent in 40.6125 rad/s or 3.1327 m/s when the force in rear wheel is 200 N. The Table 1, 2 and 3 of test result shows that the longitudinal velocity mobile robot B with disturbance (Ascent Terrain =  $30^0$ ) will convergent in 41.0978 rad/s or 3.1809 m/s when the force in rear wheel is 200 N. The Table 1, 2 and 3 of test result shows that the longitudinal velocity mobile robot B with disturbance (Ascent Terrain =  $30^0$ ) will convergent in 41.6240 rad/s or 3.3578 m/s when the force in rear wheel is 200 N. The simulation results with 3 mobile robots show accurate results.

The dynamic model nonlinear motion mobile robot has characteristic where, longitudinal velocity mobile robot will increase infinity when force rear wheel is given as constant value, but because coefficient friction value increases infinity too, then longitudinal velocity mobile robot will convergent in special value. This model just for mobile robot type car like vehicle steering.

#### 5. Acknowledgment

This study was supported by Graduate Student Program ITB / Pasca Sarjana ITB (Institut Teknologi Bandung) for facility, paper and printer and also Department of Electrical Engineering in “*Laboratorium Sistem Kendali dan Komputer*” (LSKK ITB) of Control Engineering for laboratory facility 24 hours and all facility in the Lab. The author would like to thank Dr. Hilwadi Hindersah as a thesis supervisor and all Teaching Staff of Control Systems and Computers, Electrical Engineering, Bandung Institute of Technology

#### References

- [1] Beer, F.P. and Johnston Jr, E.R. (1995), *Vector Mechanics for Engineers: DYNAMICS*, McGraw-Hill, Inc., Singapore, 16 – 38.
- [2] Hashem Zamanian, Farid Javidpour (2016), “Dynamic Modeling and Simulation of 4 Wheel Skid Steering Mobile Robot With Considering Tires and Lateral Slips”, *International Journal of Scientific Research in Knowledge*, February 2016
- [3] Chapra, S. C. and Canale, R. P. (1988), *Numerical Methods for Engineers*, Second Edition, McGraw-Hill Inc., New York.
- [4] Friedland, B. (1987), *Control System Design: An Introduction to State-Space Methods*, McGraw-Hill Book Co., Inc., Singapore.
- [5] Jean, Slotine, J.E., and Li, W. (1991), *Applied Nonlinear Control*, Prentice-Hall, Inc., New Jersey.
- [6] Johansson, R. (1993), *System Modeling and Identification*, Prentice-Hall, Inc., New Jersey.
- [7] Ljung, L. and Glad, T. (1994), *Modeling of Dynamic Systems*, Prentice Hall, Inc., New Jersey.
- [8] Ogata, K. (1997), *Modern Control Engineering*, Prentice Hall of India, India.
- [9] Petkov, Christov, and Konstantinov. (1991), *Computational Methods for Linear Control Systems*, Prentice Hall International, Englewood Cliffs.
- [10] Ramanata, P. (1998), *Optimal Vehicle Path Generator Using Optimization Methods*, Thesis submitted to the Faculty of the Virginia Polytechnic Institute and State University in partial fulfillment of the requirements for the degree of Master of Science in Mechanical Engineering, Virginia Polytechnic Institute and State University, 10 – 28.
- [11] Raven, F.H. (1995), *Automatic Control Engineering*, McGraw-Hill, Inc., Singapore, 16 – 38.
- [12] Yiyang Wang. (2002), *Robust Model Predictive Control*, A dissertation submitted in partial fulfillment of the requirements for the degree of Doctor Philosophy (Chemical Engineering), University of Wisconsin Madison, 09-29.